

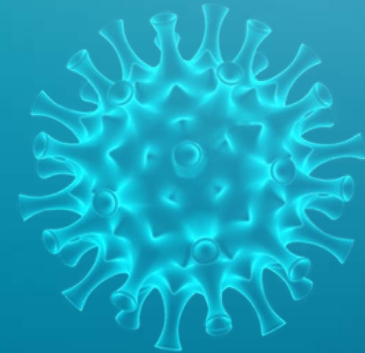

CORONAVIRUS **OUR APPROACH TO** **DECISION-MAKING**

SUMMARY



**WE ALL
MUST DO IT
TO GET
THROUGH IT**



STAY HOME



KEEP DISTANCE



WASH HANDS

We have all been affected by the Coronavirus pandemic and the measures needed to control it.

These measures have created challenges for everyone but the public's response has been very positive.

Everyone has helped save lives. As a society, we should be proud of that.

This document sets out the approach that we will adopt in the regular reviews of the Coronavirus Regulations.



The Rt Hon Arlene Foster MLA
First Minister

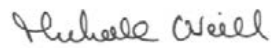

Michelle O'Neill MLA
Deputy First Minister

THE WAY FORWARD

We can now start to think about relaxing the restrictions. However, there are important factors to consider. We must remain focused on protecting our health and well-being, improving our economy and addressing the challenges we have all experienced.

We don't want to lose any of the positive changes that we have made. For example, there has been less car travel and more daily exercise. We want to encourage everyone to continue this after the restrictions end.

The steps we are all taking, both in Government and across society, are working. If we keep working together, it will let us relax in stages when the time is right.

HOW WILL WE DECIDE WHAT RELAXATIONS TO MAKE?

Any relaxation of the current restrictions will be led by science and not by the calendar. It will be based on the following criteria:

Evidence and analysis, including latest medical/ scientific advice, the level of transmission and the impact of relaxations on the future trajectory of the pandemic

Capacity of the health and social care services to deal with COVID-19 cases as well as the need to resume normal services

Assessment of the wider health, societal and economic impacts, including identifying the areas where greatest benefit and lowest risk would result from relaxation

CORONAVIRUS 'R'

We will also consider 'R', which is a measure of virus transmission. It tells us how many new people are being infected by an existing case of Coronavirus. R has now fallen to less than 1 for community transmission, meaning every case of Coronavirus currently leads to less than one additional new case. To stop the Coronavirus epidemic growing, R needs to stay at, or below, 1. So, any new relaxations must give us a reasonable chance of keeping R below 1.

R rate of 1

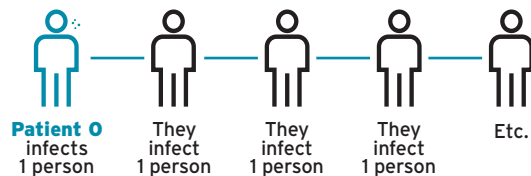

R rate of 2

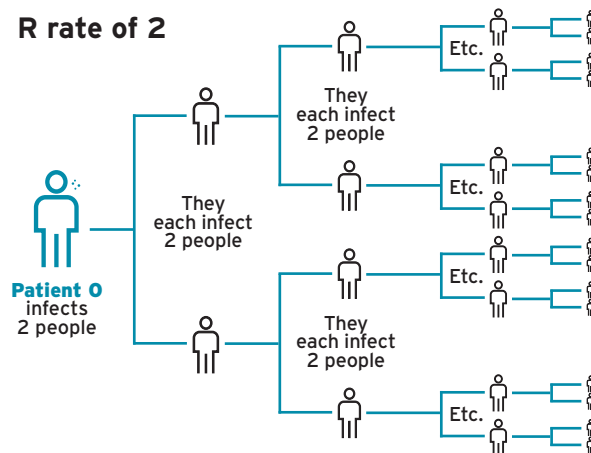

The Executive will also apply the following guiding principles when considering whether a specific restriction or requirement should be retained, removed or changed.

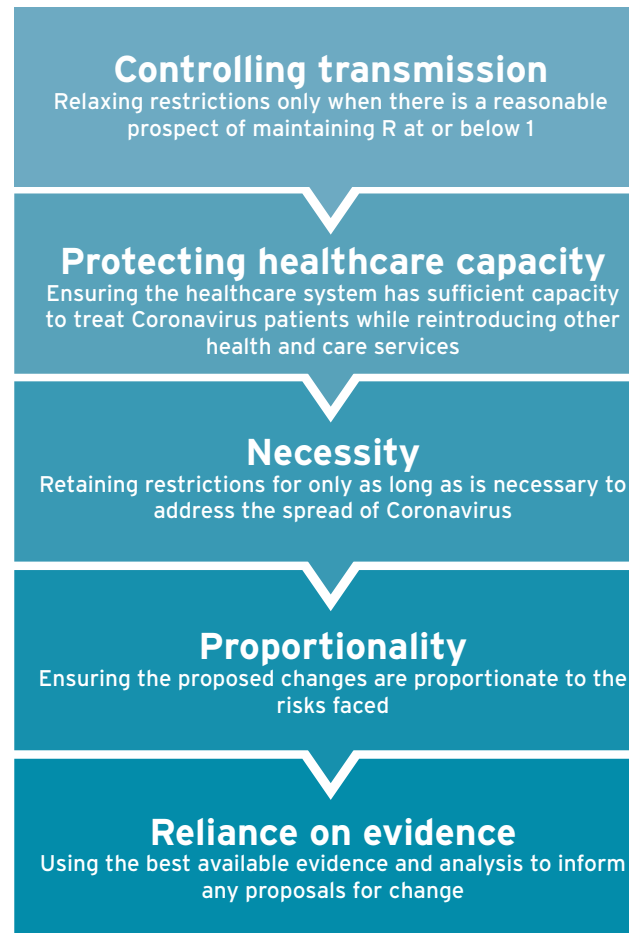

THE PATHWAY TO RECOVERY

We all want to return to a more normal way of living soon. This will take time, but we can guarantee that we will only retain the restrictions as long as they are absolutely necessary.







We know many people need to be able to plan ahead and have the hope of more normality. So we have set out below some indicative steps for the relaxation of restrictions, using the three criteria as detailed on Page 2.

This process will need to be flexible, so that it can adapt to new evidence and developments and the Executive can review and refine the approach to decision-making.

We will consider measures to reduce transmission, including the increased availability of testing, the use of surveillance or tracking methods and contact-tracing for people who have had contact with someone who has tested positive for Coronavirus.

All steps build on what is currently permitted. Steps do not necessarily apply at the same time in different sectors - e.g. Step 1 for work, may apply at a different time than Step 1 for retail, reflecting the complexity and adaptability of each environment.

Sectoral examples are illustrations, and are not intended to be comprehensive. All steps should be read with the description for the step in mind. Step descriptions are general indicators used to inform risk evaluation at each stage rather than to rigorously define permitted activities.

	Current Position	Step 1	Step 2	Step 3	Step 4	Step 5
Work (Also see note on page 5)	Work permitted subject to following legal requirements and best practice arrangements. Executive has committed to enhancing messaging around what is permissible in terms of work. Remote working is default position.	Encouragement to those unable to work from home to return to workplace on phased basis subject to legal requirements and best practice arrangements being in place.		Phased return to office and onsite working subject to risk assessment. Work that can be done from home should be done from home.		All able to return to work subject to mitigations. Remote working still strongly encouraged and maintained where possible.
Retail	Food and other permitted retail activity subject to following requirements. Many retailers only able to function using takeaway/ collection/delivery.	Large outdoor based retail can open (eg garden centres - though associated cafes and restaurants only able to offer takeaway/collection).	Non-food retail can open where numbers limited and social distancing and other mitigating measures in place as per risk assessment.		Other 'contact' retail (hairdressers, fitness studios, tattoo/piercing) can open subject to mitigations following risk assessment.	Hospitality retail (restaurants, cafes, pubs) can open subject to risk assessment, on a limited basis to start with.
Education	Schools are closed except to accommodate vulnerable pupils and the children of key workers. Measures are in place to support remote learning and to provide outreach services to vulnerable children and special needs pupils.		In addition, subject to risk assessment and adhering to maximum capacities, provision expanded to cover wider definition of key workers as workplace activity gradually increases.	In addition, schools expand provision to accommodate a number of priority cohorts on a part time basis with a blended learning approach involving a combination of in-school and remote learning.	In addition, schools expand provision to accommodate all pupils on a part time basis with a blended learning approach involving a combination of in school and remote learning.	In addition, subject to medical and scientific advice, expand early year school provision to full time basis.
Travel	Public transport will operate with limited capacity to allow for social distancing. Passengers recommended to wear face coverings and to avoid travel on busy routes/during busy periods. Enhanced cleaning regimes in place and staff on buses and trains issued with PPE in line with PHA guidance. People to be encouraged to walk and cycle for short journeys where possible.		Public transport continues to operate but will face challenges in meeting increased demand, especially on peak services, as social distancing requirements remain in place. People to be encouraged to walk and cycle for short journeys where possible.		Public transport continues to operate, but subject to ongoing risk assessment. Demand on peak services, particularly within urban areas likely to increase. Reducing and staggering demand through continued home working and staggered start times for businesses would assist as social distancing requirements remain in place. People to be encouraged to walk and cycle for short journeys where possible.	Public transport operating a full service but subject to ongoing risk assessment. Message about walking and cycling continues to be reinforced.

	Current Position	Step 1	Step 2	Step 3	Step 4	Step 5
Family and Community	Contact should be within own household.	Groups of 4 - 6 people who do not share a household can meet outdoors maintaining social distancing. With the exception of people who are shielding, visits to immediate family allowed indoors where social distancing is possible. Drive through church services and churches open for private prayer with appropriate social distancing and cleaning of shared contact hard surfaces.	Groups of up to 10 can meet outdoors.	Gatherings can accommodate up to 30 people while maintaining social distancing.	A wider range of gatherings permitted including church services subject to social distancing and other suitable mitigations, such as cleaning of hard surfaces.	Can meet in extended groups subject to social distancing or other suitable mitigations.
Sport, cultural and leisure activities	Exercise permitted.	Outdoor spaces and public sport amenities to open. Can undertake for example, walking, running, cycling, some water activities, golf, tennis. Drive through cinema.	Resumption of, for example, team sports training on a non-contact basis in small groups. Selected libraries open, restricted services. Open air museums re-open.	Resumption of, for example, team sports training on a non-contact basis. Museums and galleries open. Libraries open. Concert and theatre rehearsals resume.	Resumption of, for example, competitive sport 'behind closed doors' or with limitations on the number of spectators. Leisure centres and other indoor leisure facilities open. Outdoor concerts on restricted basis.	Resumption of close physical contact sports. Return to competitive sport and full use of sporting facilities. Spectators to attend live events on restricted basis. Nightclubs, concerts open on a limited basis.
Definition of steps	Regulations define what is currently permitted.	Outdoor activities (work and leisure) during which social distancing can be maintained for individuals who do not share a household contact and where there is no shared contact with hard surfaces.	Indoor activities involving limited contacts of less than 10 mins and interactions of only 2-4 people that maintain social distancing and prevent congregating in places for any extended period. Outdoor activities involving small groups of less than 10 people during which it may be difficult to maintain social distancing but where contacts are brief (less than 10 minutes).	Indoor activities involving larger number of individuals where social distancing can be maintained for individuals who do not share a household connection. Outdoor activities involving larger groups of less than 30 people during which it may be difficult to maintain social distancing but where contacts are brief (less than 10 minutes).	Indoor activities involving larger numbers of individuals where social distancing cannot be consistently maintained but contacts are limited and last less than 10 minutes or longer if effective mitigation is possible. Outdoor gatherings involving larger numbers of individuals where social distancing cannot be easily maintained and multiple contacts of less than 10 minutes are likely.	Indoor gatherings of large numbers of people where social distancing cannot be easily maintained and multiple contacts of more than 10 minutes are likely.

Note: The scope to work depends on the ability to take the appropriate mitigating measures. Significant work has been done on these issues by business and trade union representatives under the Engagement Forum chaired by the Labour Relations Agency which resulted in the Workplace Safety Guide. This sets out principles and practical steps to keep workplaces safe. This guidance should be read in parallel with that work and more information is available at the links below.

<https://www.nibusinessinfo.co.uk/content/coronavirus-workplace-safety-guidelines-and-social-distancing>
<https://www.nibusinessinfo.co.uk/content/coronavirus-workplace-safety-guidance-and-priority-sector-list>

IN CLOSING

It's really important that we all continue to:



Follow the advice being offered by the Government based on medical and scientific evidence, including the current **#stayhome** advice while that remains in place;



Wash our hands regularly and in line with the best practice guidance;



Have good respiratory hygiene in terms of coughing or sneezing into a tissue or the crook of your elbow;



Follow the social distancing guidelines and stay two metres away from those outside your household whenever possible;



Consider the use of cloth face coverings (mouth and nose) for short periods of time when you are in enclosed spaces where social distancing cannot be maintained. For example when using public transport and while in some shops; and



Abide by the need to self-isolate either because you have symptoms or because you have been in touch with someone who has symptoms or has tested positive for Coronavirus. This includes if contacted by the contact tracing arrangements in place.

We also ask those in society with responsibilities to exercise them in line with up-to-date public health guidance. So there is an onus on businesses, schools, churches, sporting organisations and many others to show how they can accommodate the current social distancing and other requirements if they are seeking agreement to recommence their activities.

For example, for businesses, that means meeting their legal duty and following best practice for their workforce by ensuring social distancing is observed wherever possible and by meeting all of the other relevant guidance. This will require many businesses and their employees to find new working practices.

If we continue to follow the latest guidance, we will have the best chance of successfully reducing the transmission of the disease and in recovering from the major health, societal and economic damage that has been done to our community. That, in turn, will put us in the best possible place for future growth on all fronts.

ADVICE AND SUPPORT

Get the most up-to-date information on any government services affected by coronavirus at: nidirect.gov.uk/coronavirus

COVID-19 Community Helpline

If you have been advised by your GP to 'shield' for 12 weeks, are an older person or vulnerable, you can contact the freephone COVID-19 Community Helpline. You will get advice and access to lots of support services, including food, medication or emotional support.

Freephone: **0808 802 0020**

(7 days per week, 9am-5pm)

Email: Covid19@adviceni.net

Text: **ACTION** to **81025**

Benefits

If you currently receive benefits, you will continue to receive your payments and are excused from signing.

If your employment has been affected by coronavirus, find out about benefits including Universal Credit at: nidirect.gov.uk/coronavirus

Rural Support

For help and support for farmers and rural families go to: ruralsupport.org.uk or freephone **0800 138 1678**

Lifeline

If you or someone you know is in distress or despair Lifeline are there to help 24/7 on freephone **0808 808 8000**. And visit mindingyourhead.info for more advice on mental health.

SUPPORT FOR BUSINESSES AND EMPLOYEES

nibusinessinfo.co.uk

Get business support, advice and guidance including financial support schemes, policy information and help with managing current challenges at: nibusinessinfo.co.uk/coronavirus

Invest NI

Find business continuity programmes, advice and support covering strategy, finance, people, operations and innovation at: investni.com/covid19response

MEDICAL INFORMATION AND ADVICE

More help and advice is available from these organisations.

Department of Health

Download the Covid-19 NI app for the latest information and advice. Search for Covid-19 NI in your app store.

NHS

You can ring **NHS 111** for information or advice and they will help you decide if you need to contact your GP.

Public Health Agency NI

Get the latest health information and advice at: pha.site/coronavirus

GP

Only phone your GP if you have an underlying health condition and develop symptoms, if you feel you cannot cope with your symptoms at home, or if your condition gets worse. To protect yourself and others, do not go to a GP, pharmacy or hospital if you feel unwell.